

VIBRATORY BIN AERATORS



SAIDEEP

Technology That Lays The Foundation Of Your Dreams...



VIBRATING BIN AERATOR

Saideep's Unique umbrella shape provides dual advantage of cleaning side walls of silo and fluidizes the material simultaneously, guaranteeing uninterrupted flow of material through silo cone.

Salient Features & Benefits

1. Made out of specially developed heat resistant, high tenacity silicon rubber (Food Grade) with stainless steel struct for inert gas purging.
2. Suitable to withstand temp. From -70 to 170 degree Celsius.
3. Easy Interchangeability. Ex-Stock delivery.
4. Lower operating pressure.
5. Reduced air consumption.
6. Unique high efficiency design.
7. Comprehensive product range.
8. Retrofit design.
9. Interchangeable with other aerator makes.
10. Quick installation.
11. Food-grade.



Dimensional Drawing for Vibrating Bin Aerator

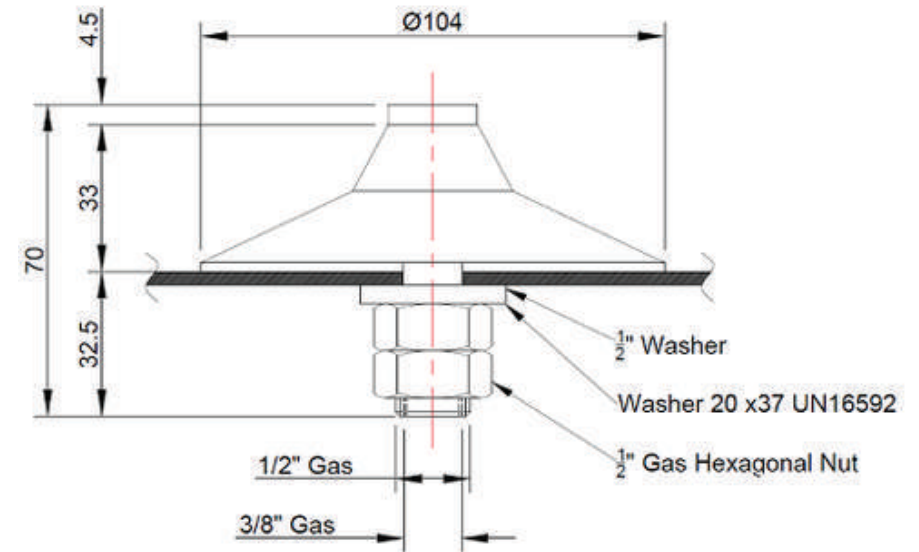

Bin Aerator					
Air Consumption					
2 Bar (29 psi)		4 Bar (58 psi)		6 Bar (87 psi)	
L/min	Cfm	L/min	Cfm	L/min	Cfm
100	3.53	150	5.29	250	8.82



www.saideeponline.com

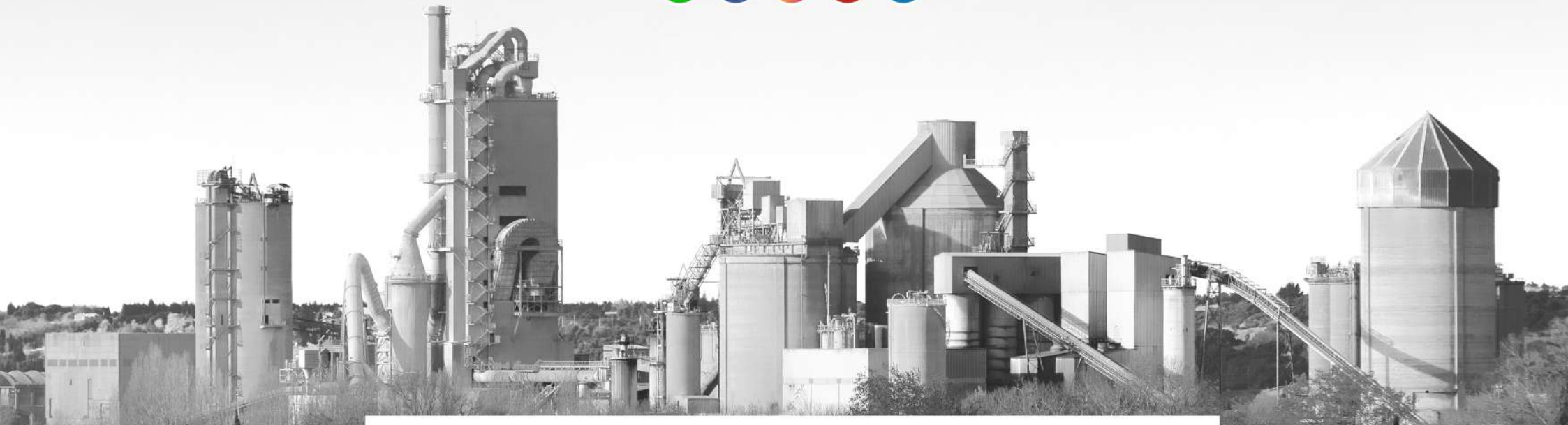

(022)-2685 5843/5799
+91 9867024202



A-11, Laghu Udyog Kendra, L.B Patel Road,
Goregaon East, Mumbai - 400063,
Maharashtra, India.



sales@saideeponline.com
saideep55@yahoo.com