



**SAIDEEP**

*Technology that lays the foundation of your dreams*

# Bin Activator



- Ensures smooth, continuous flow
- Easy to operate
- No dusting or spillage of material
- No loss of production
- Handles material gently without damaging particles

# Bin Activator

## Saideep Heavy Duty Bin Activator (Model-SBAH)

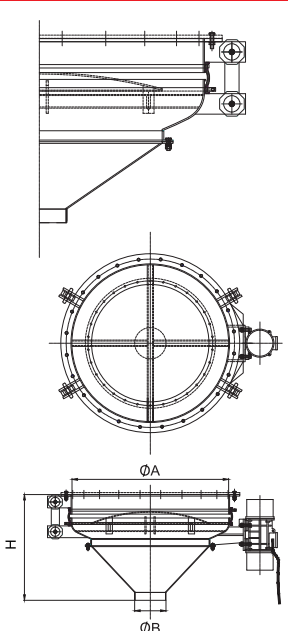

Model	A	B	H	Motor (KW)
SBAH - 450	450	150	400	0.16
SBAH - 600	600	150	475	0.35
SBAH - 750	750	150	525	0.62
SBAH - 900	900	200	675	0.65
SBAH - 1000	1000	200	675	0.65
SBAH - 1200	1200	200	675	1.15
SBAH - 1250	1250	200	675	1.15
SBAH - 1500	1500	200	825	1.15
SBAH - 1750	1750	200	950	1.6 x 2
SBAH - 2000	2000	250	1075	2.5 x 2
SBAH - 2500	2500	250	1230	2.5 x 2
SBAH - 3000	3000	250	1600	3.6 x 2

Some times material stored in hopper does not flow easily due to the peculiar design of hopper or due to Inherent Non-flowing properties of the material in such situation the normal solution is to employ Bin Vibrators, Air Jets, Manual Poking or Hammering. This normally leads irratic discharge of material with noisy operation.

It is here that "SAIDEEP" Bin Activator plays an important role in solving material flow problem caused by Wedging, compacting or Rat Holding of material in taper zone at discharge end of the hopper.

### OPERATION :

SAIDEEP Bin Activator consist of conical shape discharge zone which is connected to storage silo or hopper through a set of steel hangers. The gap between the hopper and discharge zone is sealed by one special flexible sleeve made of rubber.

### APPLICATIONS :

- Food Products • Pharma • Chemicals • Aggregates
  - Coal, Fly Ash, Briquettes • Plastics • Pigments
- They can be used with any silo containing powders that do not flow out easily.

### FEATURES :

- Heavy Duty suspensions.
- 360-Degrees Movement (For SABL Series)
- High Durable Rubber Bellows. (Natural Rubber, Silicone, Neoprene)
- Ensures Material Flow on FIFO basis.
- Highly Quality Vibro Motors. (FLP Motors Available On Request).

### WIDE RANGE :

- Available for silos from 400 mm dia. to 3000 mm dia.
- Made from M.S., S.S.- 316 or abration resistant steel.
- Epoxy coated or teflon coated for food application.

## Saideep Light Duty Bin Activator ( Model-SBAL )

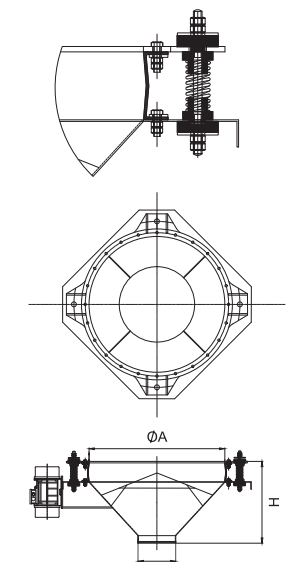

Model	A	B	H	Motor (KW)
SBAL - 400	400	150	312	0.16
SBAL - 600	600	150	417	0.16
SBAL - 750	750	200	466	0.3
SBAL - 900	900	200	541	0.3
SBAL - 1000	1000	250	566	0.35
SBAL - 1250	1250	250	691	0.35
SBAL - 1500	1500	300	785	0.65
SBAL - 1800	1800	300	935	0.65 x 2
SBAL - 2100	2100	400	1036	0.65 x 2
SBAL - 2500	2500	400	1316	1.15 x 2
SBAL - 3000	3000	400	1566	1.15 x 2

## Our other products :



Office : A-11, Laghu Udyog Kendra, I. B. Patel Road, Goregaon (East), Mumbai - 400 063.  
 Phones : (022) 2685 5799 / 2685 5843 • Mobile : 9867024201  
 Email : sales@saideeponline.com / saideep55@yahoo.com  
 Website : www.saideeponline.com

Factory : Plot No. 17 & 18, The Palghar Taluka Inds. Co-op. Estate Ltd.,  
 Palghar Boisar road, Palghar (West) 401 404.

